



Joseph Leckie  
Academy

2021



**PARENT INDUCTION BOOKLET  
JOSEPH LECKIE ACADEMY**

## ABOUT THIS BOOKLET

This booklet contains some vital information, to support you and your child with transition. If you have any questions regarding the information contained within this booklet, please do not hesitate to contact the Academy at [transiton2021@josephleckieacademy.co.uk](mailto:transiton2021@josephleckieacademy.co.uk) or Academy reception on 01922 721071.

## CONTENTS

Principal's Welcome	—	Page 3
Mission Statement	—	Page 4
Transition to Joseph Leckie Academy	—	Page 5
Message from Head of Year 7	—	Page 6
Safeguarding	—	Page 7
Important Dates for Your Diary	—	Page 8
Academy Day for Year 7	—	Page 9
Lunch at the Academy	—	Page 9
Attendance and Punctuality	—	Page 10
Ready to Learn	—	Page 11
Mobile Phones and Electronic Devices	—	Page 11
Academy Uniform	—	Page 12-13
Curriculum, Homework, Gifted-Talented	—	Page 14
Student Support	—	Page 15
Learning Support (SEND)	—	Page 16
Extra-curricular and Enrichment	—	Page 17
Pledges	—	Page 17
Physical Education	—	Page 18
Academy PE Kit	—	Page 19
Academy House System	—	Page 20
Library	—	Page 21
Academy Site Map	—	Page 22
FAQ	—	Page 23



# WELCOME TO JOSEPH LECKIE ACADEMY

**Dear Parent/Guardian**

Thank you for choosing Joseph Leckie Academy for the secondary education of your child. We look forward to working with you as we face the future together. The Academy has a proven record of excellence in our academic work with some superb results over a number of years and we are one of the best schools in Walsall for student progress. We are also a recognised leader in caring for the social, emotional, and personal development of our students.

We know that you will want to join with the staff of the Academy in supporting us and together supporting your child in developing the knowledge, skills and essential understanding for their life-long learning. Co-operation between us is essential and the Academy is always open for you to visit.

There are so many opportunities available for students within the curriculum and beyond the Academy. For example, all students will be a part of the Academy House system and the Heads of House, along with staff, plan a whole range of fun and exciting competitions and activities throughout the year. We also have a Pledge system whereby students volunteer their time and contribute to the Academy or wider community. In addition, there are a wealth of external curriculum based trips as well as our Activities days in the Summer term.

We hope that your child will make full use of all opportunities we provide and that you will be involved with us in promoting and supporting the education of your child. Together we can ensure that they achieve success and happiness in their time with us at Joseph Leckie Academy - we look forward to working with you and sharing in your child's achievement and success.

Yours sincerely,

**James Ludlow**

Principal



## **MISSION STATEMENT**

Joseph Leckie Academy provides a safe but challenging environment which maximises opportunities for all members of the community. We work in partnership with parents to equip all of our students to be confident and effective young people and lifelong learners.

### **Our Main Aims are to:**

#### **Develop:**

Fully develop the talents of all our students so that they achieve their full potential whilst helping them to understand the positive benefits of working with others.

#### **Inspire:**

Inspire creative and imaginative thinking whilst increasing their skills of independent enquiry.

#### **Promote:**

Promote the growth of sound morality and lay the foundations for a happy, successful and healthy adult life.

#### **Encourage:**

To equip students with a positive attitude to learning and life; be equipped with the skills that will enable them to participate effectively in an ever changing society.

#### **Respect:**

To produce a greater level of respect for themselves and others, by developing an awareness of the role and contribution of the individual within a local, national and international context.

## TRANSITION TO JOSEPH LECKIE ACADEMY

We at Joseph Leckie Academy, anticipate that your child may be little nervous or a little unsure about starting secondary school in September. Rest assured there is nothing to worry about, as we are all in this together.

My name is Miss Ravat and I am overseeing Transition this academic year. I believe that the notion of care is to provide every child with the opportunity to be successful and a personal approach to their individual learning needs to ensure that 'no child is left behind'. At Joseph Leckie, we aim to provide your child with a fulfilling and enjoyable learning experience, which will enable them to gain excellent qualifications and explore a range of different extra-curricular opportunities via our 'House System'.

Furthermore, once students arrive at the Academy, our Year 7 Pastoral team led by Ms Etches will continue to support them with their academic and pastoral needs.

I look forward to welcoming you and your child to our Academy.

Regards,

**Miss N Ravat**

Associate Assistant Principal





## MESSAGE FROM HEAD OF YEAR 7

Hello and welcome to Joseph Leckie Academy. My name is Ms Etches and I will be the new Head of Year 7. I have worked in education for over 25 years. This is now my 8th year here at JLA.

Joseph Leckie Academy is proud of its achievements, and is a school where students receive praise, support and challenge. We are persistent in our pursuit of high standards and excellent teaching.

We expect great things from our students and a strong work ethic and motivation to succeed are vital. Teachers and parents are required to work together in partnership to ensure students make excellent progress. Joseph Leckie Academy aims to offer every student the opportunity to do their very best. We have high expectations for behaviour and attendance.

Communication is paramount, if I don't know I can't try to 'fix it'. Every child has a voice and every voice will be heard...I look forward to seeing and working with you all very soon.

Regards,

**Ms D Etches**

Head of Year 7



## SAFEGUARDING

### What is safeguarding...

Safeguarding and promoting the welfare of children is defined as: protecting children from maltreatment; preventing impairment of children's health or development; ensuring that children grow up in circumstances consistent with the provision of safe and effective care; and taking action to enable all children to have the best outcomes possible.

### Designated Safeguarding Personnel at the Academy

Mrs M DeRome	—	Associate Assistant Principal	—	DSL / SPOC*
Mr J Ludlow	—	Principal	—	Deputy DSL
Miss R Cook	—	Vice Principal	—	Deputy DSL
Mrs J Smith	—	Vice Principal	—	Deputy DSL
Mr A Banbery	—	Assistant Principal	—	Deputy DSL, Leadership link to Y7
Mr T Pochin	—	Assistant Principal	—	Deputy DSL
Mrs L Price	—	Assistant Principal	—	Deputy DSL
Mr J Greaves	—	Assistant Principal	—	Deputy DSL

*\*DSL— Designated Safeguarding Lead , SPOC—Single Point of Contact*

To ensure our students and staff are kept safe we have a number of policies and procedures in place, which are understood and followed by all staff, governors and volunteers.

All of our safeguarding related policies are available on our Academy website page at [www.josephleckieacademy.co.uk](http://www.josephleckieacademy.co.uk)

### Safeguarding Is Everyone's Responsibility

Please feel free to contact any member of the Leadership Team if you are concerned about the safety of a student from Joseph Leckie Academy.

However, if a child is in immediate danger, please contact:

Police — 999 (emergency) or 101 (non-emergency)

Walsall MASH / Initial Response Service — 0300 555 2866

Walsall Safeguarding Children Board — 01922 658409

Or if you would like further advice or guidance please contact:

NSPCC — 0808 800 5000

ChildLine — 0800 11 11

Samaritans — 116 123

## IMPORTANT DATES FOR YOUR DIARY



Monday 6th September	—	<i>Phased return for Year 7 students (Please see separate letter)</i>
Monday 6th September and Tuesday 7th September	—	<i>Year 7 Photographs</i>
Monday 27th September to Friday 22nd October	—	<i>Year 7 Form Tutor Calls to Parents</i>
Thursday 31st March	—	<i>Year 7 Parents Consultation Evening</i>
Friday 17th June	—	<i>Year 7 Reports Issued to Parents</i>

## TERM DATES FOR 2021 – 2022

<b>Term 1</b>	—	<b><i>Monday 6th September – Friday 22nd October</i></b>
Half Term	—	<i>Monday 26th October – Friday 30th October</i>
<b>Term 2</b>	—	<b><i>Monday 1st November – Friday 17th December</i></b>
Christmas Break	—	<i>Monday 20th December – Friday 31st January</i>
<b>Term 3</b>	—	<b><i>Monday 3rd January – Thursday 17th February</i></b>
Half Term	—	<i>Monday 21st February – Friday 25th February</i>
<b>Term 4</b>	—	<b><i>Monday 28th February – Thursday 7th April</i></b>
Easter Break	—	<i>Friday 8th April – Friday 22nd April</i>
<b>Term 5</b>	—	<b><i>Monday 25th April – Friday 27th May</i></b>
Half Term	—	<i>Monday 30th May – Friday 3rd June</i>
<b>Term 6</b>	—	<b><i>Monday 7th June – Thursday 21st July</i></b>
Summer Holidays		

Please be aware, that on occasions, dates may need to alter slightly. You will be notified in good time should this happen.



## ACADEMY DAY FOR YEAR 7

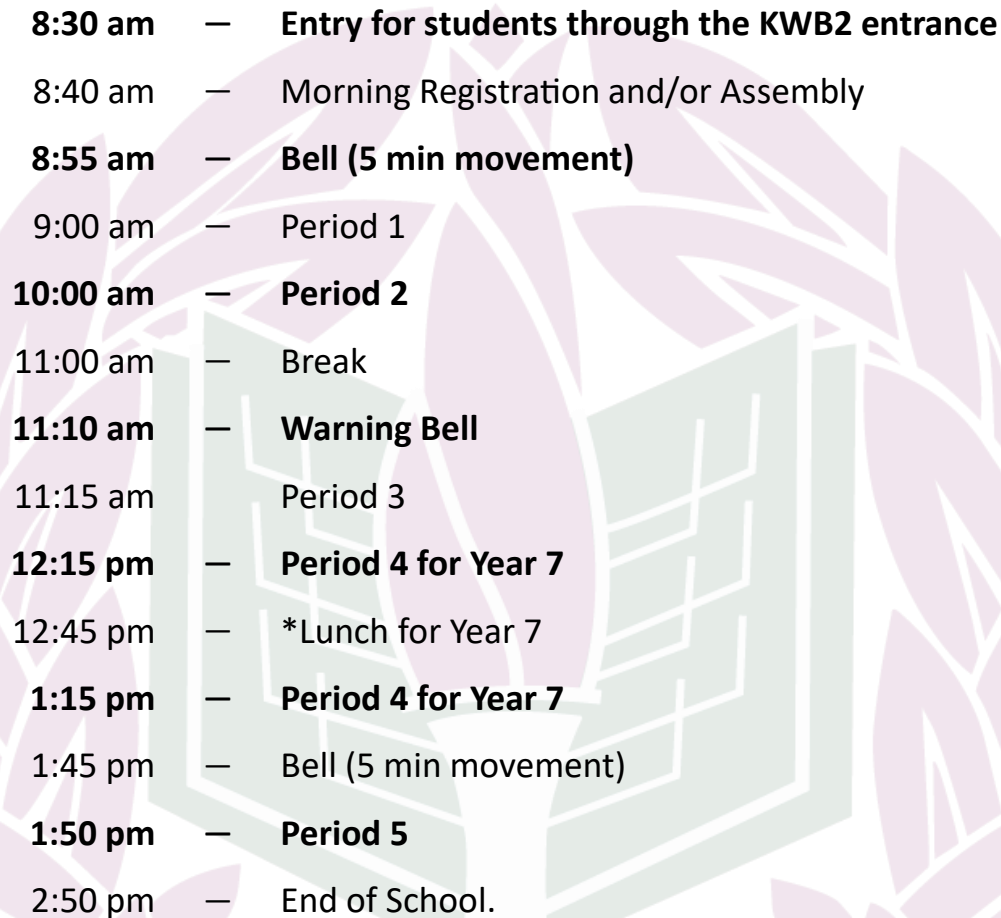

<b>8:30 am</b>	—	<b>Entry for students through the KWB2 entrance</b>
8:40 am	—	Morning Registration and/or Assembly
<b>8:55 am</b>	—	<b>Bell (5 min movement)</b>
9:00 am	—	Period 1
<b>10:00 am</b>	—	<b>Period 2</b>
11:00 am	—	Break
<b>11:10 am</b>	—	<b>Warning Bell</b>
11:15 am	—	Period 3
<b>12:15 pm</b>	—	<b>Period 4 for Year 7</b>
12:45 pm	—	*Lunch for Year 7
<b>1:15 pm</b>	—	<b>Period 4 for Year 7</b>
1:45 pm	—	Bell (5 min movement)
<b>1:50 pm</b>	—	<b>Period 5</b>
2:50 pm	—	End of School.

\*The time at which students have lunch depends on the year group they belong to.

## LUNCH AT THE ACADEMY

All Year 7 students will have lunch between 12:45pm to 13:15pm in the canteen. The Academy lunches and break-time food services are provided by Aspens. Aspens carefully plan menus with well balanced meals, to support students throughout the day and further help with concentration and behaviour.

At the Academy, we use a biometric cashless (finger print) system. This means that students will no longer have to carry lunch money, instead when paying for lunch their fingerprint will be scanned and payment taken from their academy account. Money can be loaded onto the students' account via ParentMail, our online payment system. The Academy will also be introducing an ID card payment system in addition to this.

If your child is entitled to Free School Meals, please ensure you have completed the online application form.

## ATTENDANCE AND PUNCTUALITY

Regular attendance at the Academy is vital to help your child achieve and get the best possible start in life. Children who frequently miss school often fall behind. There is a strong link between good attendance and achieving good results. Please do not book holidays during term time as leave will only be granted in exceptional circumstances. Where possible, please also keep medical appointments outside of the normal academy day.

If your child is unable to attend the Academy, please notify the Academy as soon as possible.

Punctuality is just as important as good attendance. Being punctual means making sure your child is at school and ready to learn before the bell goes. Please ensure your child eats a healthy breakfast and arrives by 8:30am every day. We also have a breakfast club available at the Academy and your child can attend this, free of charge, from 8:00am every day. This will commence from Monday 13<sup>th</sup> September 2021.

Lost minutes means lost learning and therefore it is equally important that your child gets to the start of every lesson on time.



## READY TO LEARN

To ensure your child makes the very best of their learning opportunities, students are expected to have the following items with them during every school day:

- Pens (black, blue, green (for carrying out corrections))
- Pencils
- Ruler
- Rubber
- Pencil sharpener
- Reading Book
- Student Planner – Provided by the Academy
- PE Kit (On days they have PE)

Students will also benefit from having a Casio FX83GTX calculator.

It is highly recommended students bring a school bag pack to keep their personal belongings and a pencil case to contain their stationery.

Stationery and a fully equipped pencil case is available to purchase from the Academy via ParentMail.

## MOBILE PHONES AND ELECTRONIC DEVICES

Mobile phones and other electronic devices are not allowed to be used on the Academy premises at any time. We operate an “on site, out of sight” policy so in the event that your child does carry a mobile phone/electronic device to the Academy, this must not be seen or heard from the moment they come through the Academy gates. If a mobile phone is seen / used during the Academy day, it will be confiscated and only returned when a parent or carer collects it from the Academy after 2:50pm.

If you need to contact your child during the Academy day, please contact the Academy Reception and we will get a message to your child as soon as possible.





Joseph Leckie Academy

# Academy Uniform



Joseph Leckie Academy

## Boys

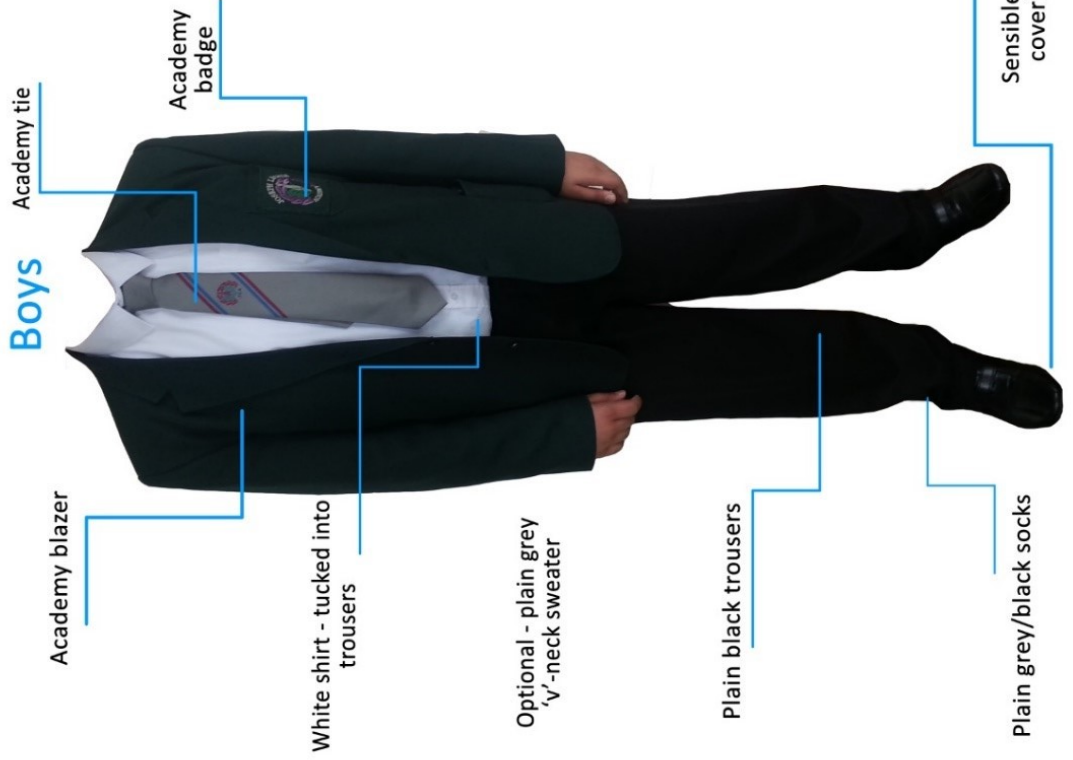

## Girls

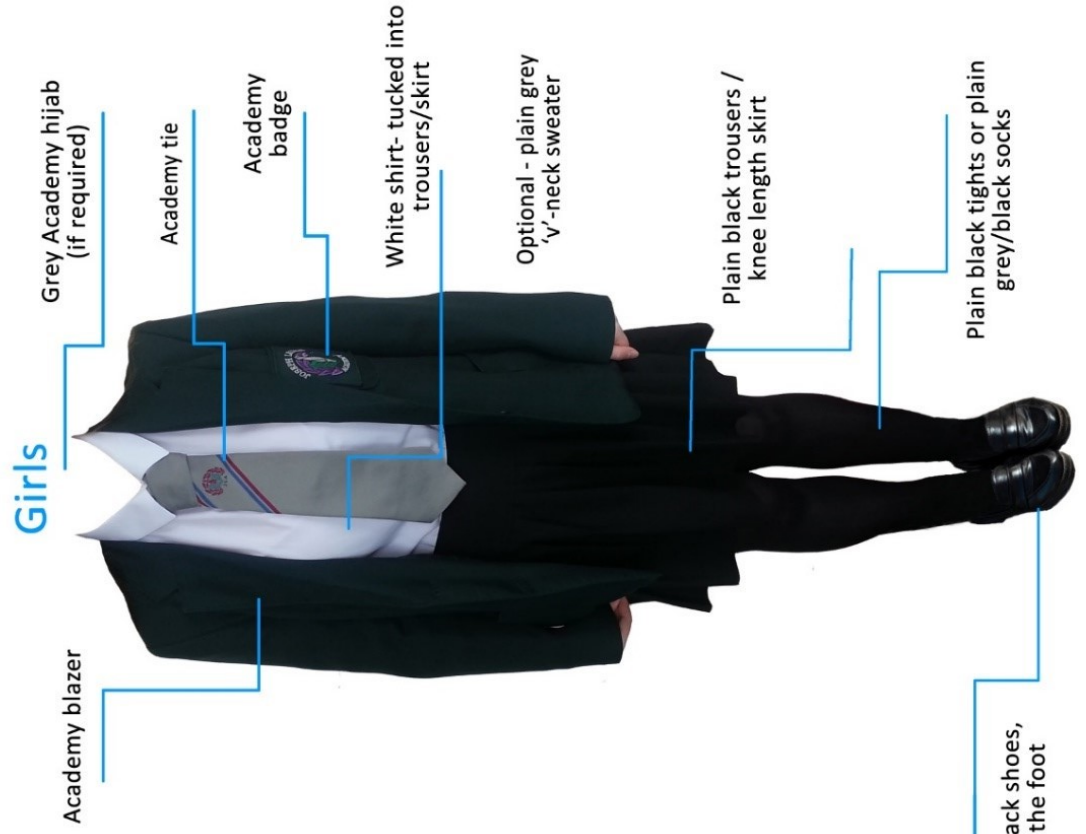

# ACCEPTABLE UNIFORM GUIDE

## Acceptable Uniform ✓



## Unacceptable Uniform ✗



The Academy uniform and PE kit can be purchased from Clive Mark (Walsall) , Clemmy's (Darlaston) and Crested Schoolwear (Walsall).

## **KEY STAGE 3 CURRICULUM**

Throughout years 7 and 8, Key Stage 3 students will experience the full statutory range of subjects of the National Curriculum, including citizenship, religious education, sex and relationship education and other aspects of PSHE and careers education.

Students are taught within two equal ability bands called J and L and are placed into sets within these bands based on prior attainment and ability in a specific subject. Subjects studied at this stage allow students to engage in a full range of learning and provide excellent foundations for GCSE study, which begins in Year 9.

We believe the curriculum should be relevant, engaging and interesting and enable students to make good progress through effective differentiation according to need.

## **HOMEWORK**

At the Academy, we believe that regular homework is vital in securing the very best results for our students. Homework also provides opportunities for reinforcement of work learned during school time and for children to develop their research skills. Students are encouraged to record homework set each day in their planners. The Academy Homework Timetable is available on our website.

## **GIFTED AND TALENTED**

The gifted and talented focus at JLA is about taking students identified as being high ability in their subjects and stretching them further.

We, as an Academy, recognise that there is no such thing as a typical gifted or talented student. Each is an individual and demonstrates widely differing patterns of behaviour, skills, aptitudes and attainments.

Some students coming into the Academy may already show behaviours and attitudes associated with being gifted and talented. If you believe your child should be considered for gifted and talented, please complete the Gifted & Talented Form on our website's Transition page.

If your child is identified as gifted or talented, they will receive a range of support from their subject teachers and myself, as the gifted and talented coordinator.



## STUDENT SUPPORT

Our Student Support Centre works alongside all Head of Years and Staff at Joseph Leckie Academy to ensure the wellbeing and happiness of your child. This is paramount to us to ensure their individual success not only at school but for their future.

Starting Secondary school can be very daunting not only for your child but for you as their Parent/Carer. We are here to liaise with you and to meet all the needs of your child. We are available for advice, questions, referrals and any information you may require or may be worried about to put your mind at ease.

Services we provide to the students at the Academy include:

- One to one mentoring to discuss problems and solutions.
- Individual and group sessions delivering particular programmes of work.
- Support with transition for new students and students with specific needs. This includes individualised timetables to support with integration.
- Help with coursework, home work and organisational skills.
- Referrals to external agencies to support students.
- Help students to overcome barriers to learning.
- Raise achievement and attainment.
- Improve individual social skills and increase self-esteem, confidence and alleviate anxiety.
- Motivate disengaged students.

Our door is always open!

**Sarah Smith**

Student Support Manager

## LEARNING SUPPORT (SEND)

I am Mr Wallworth, the Head of Learning Support. I have been in post three years and have a team of 18 Teaching Assistants. We will all be working closely with the Head of Year to ensure that your child's transition to Joseph Leckie Academy meets their individual needs.

At Joseph Leckie Academy, we recognise that transition can be a difficult time for all children especially children with additional needs. I would like to take this opportunity to assure you that we will take steps to ensure that your child's move from their primary school to Joseph Leckie Academy will be as smooth as possible.

Even during these difficult times, we have been working in partnership with our feeder schools to ensure we have as much information about your child as possible, to support their move and understand their preferred learning style. Your child's transition to our Academy is a key priority to me and I will be available to discuss this with you via email or on the telephone.

All students with additional needs benefit from a personalised pupil passport and this will be completed with the support of a Teaching Assistant and shared with all teachers. Furthermore, my team of Teaching Assistants and I will do all we can to ensure we are here to support yours and your child's needs.

If I can be of any further assistance, please do not hesitate to contact me.

Regards,

**Mr Wallworth**

Head of Learning Support



## Extra-Curricular and Enrichment

At the Academy, we are passionate about encouraging our students to develop a wide range of life skills and offer a variety of activities to help them achieve this.

Some of the activities available are:

French Club	Song Writing Club	Table Tennis
Maths Drop In	Swimming	Choir
Basketball	Boxercise	History Club
Minecraft Club	Duke of Edinburgh	Trampolining

The Academy also organises an extensive range of trips, activities and residential during activity days in the Summer Term. These activities provide students with a wealth of new experiences as well as motivate and reward them for successfully completing the academic year.

## Pledges

At the Academy, we believe that students should have a rounded experience, built on achieving the best possible academic outcomes and engaging with as diverse and broad an experience of Academy and community life as possible.

In order to further develop this ethos, raise expectations around the importance of engagement from everyone and to celebrate success, we have Pledges. Students are awarded Pledges for their wider contribution to Academy and local community life. Pledges are designed to help students gain confidence, increases self-esteem, and opens up opportunities to them within the Academy.





## PHYSICAL EDUCATION

### PE Lessons at JLA

All students will have two lessons of PE a week in Year 7. PE allows your child to develop lots of skills such as team work, communication and organisation. It is also vital for their physical and mental wellbeing.

At various times of the year they will take part in a range of physical activities. These will include; swimming, football, rugby, volleyball, gymnastics, athletics, softball and rounder's.

### Extra-Curricular Opportunities

All students are encouraged to take part in extra-curricular clubs while at JLA. A variety of clubs are offered at lunch time and after school for students to get involved in. These include; cricket, table-tennis, basketball, swimming, football, volleyball, dance, cheerleading and badminton.



### Team and House Competitions

Students are encouraged to take part in a range of house competitions across the academic year. Through taking part, they are awarded with points which go towards their House total.

As well as House competitions, students also compete in a range of activities / sports against other Walsall schools.





Joseph Leckie Academy

### SWIMMING KIT

- Black swimming costume or swimming trunks
- Towel
- Swimming Hat
- Goggles (optional)



Joseph Leckie Academy

### HEALTH AND SAFETY

- All long hair must be tied back.
- No jewellery to be worn for any PE lessons / clubs.
- Football boots must be worn for football / rugby.

# Academy PE Kit

## BOYS AND GIRLS



Green - Hercules



Blue - Orion



Red - Perseus



Yellow - Zodiac

### Joseph Leckie House Polo Shirt



Black Tracksuit

Bottoms



Black 1/4 Zip Top

Black sweater



Black Shorts

(optional)



White Football Socks



Trainers

Can be any colour, but they must support the foot and ankle (no pumps)



Football Boots



Shin Pads

## ACADEMY HOUSE SYSTEM

Our main aim at Joseph Leckie Academy is to ensure your child leaves school equipped with the tools needed for life. The most obvious way to do this is to achieve good exam results but we know there is more to Academy life than this. This is where the house system comes in!

The Joseph Leckie Academy house system runs competitions all year round that are both academic and hobby based. Each student has a duty to compete in competitions, representing their house when they do. Over the past 12 months the house team have coordinated competitions from a wide range of different areas; from Basketball to Bake-offs, from International Women's Day to D-Day Art competitions, from French Café Menu design to FIFA tournaments. Our aim is to ensure every student has at least one competition that they will enjoy taking part in.

By assigning each student to a house and running competitions we aim to develop a sense of pride and belonging in students, making them feel they belong to the Academy family. The competitions also promote a healthy competitive nature and ensure students are ready for highs and lows later in life. The four houses at Joseph Leckie Academy are based on the Constellations, they are...



Hercules house is led by Mr Barron and are named after the Greek Mythology hero. Hercules members wear Green.



Orion house is led by Miss Ahmed and are named after a Hunter from Greek Mythology. Orion members wear Blue.



Perseus house is led by Mr Taylor and are named after the Greek Mythology hero. Perseus members wear Red.



Zodiac house is led by Mr Potter and are named after a group of Stars in the sky. Zodiac members wear Yellow.





## LIBRARY

At Joseph Leckie Academy, we encourage students to read as much as possible. Evidence suggests that children who read for enjoyment every day not only perform better in tests than those who don't, but also develop a broader vocabulary, increased general knowledge and have a better understanding of other cultures.

The Library is your child's gateway to a wealth of resources to help with homework, projects, research and reading for pleasure. The Library has over 15,000 books (fiction and non-fiction), online subscriptions and eBooks. We also have a qualified Librarian to help your child with their homework, research and reading.



# ACADEMY SITE MAP

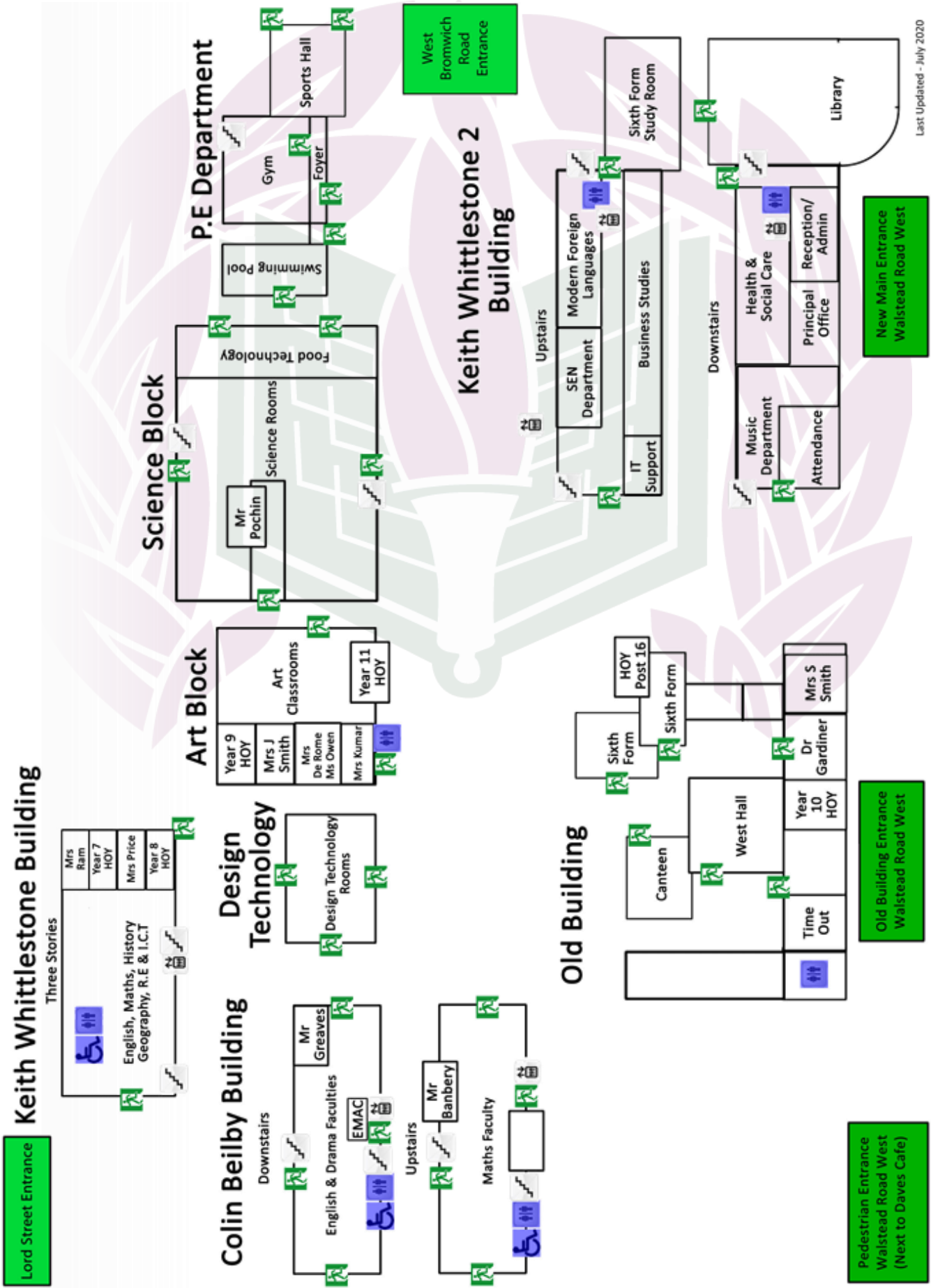

Last Updated - July 2020

## FREQUENTLY ASKED QUESTIONS

### **Who do I contact for any Transition queries?**

Miss Ravat is the Academy lead for Transition and can be contacted by email on [transition2021@josephleckieacademy.co.uk](mailto:transition2021@josephleckieacademy.co.uk)

You can also contact the Academy reception on 01922 721071, to leave a message.

### **How can I keep up to date with the latest information regarding Transition?**

Please feel free to continue visiting the Transition page on the Academy website at <https://www.josephleckieacademy.co.uk/transition2021>

or alternatively visit our social media pages on

<https://www.josephleckieacademy.co.uk/page/?title=Academy+Social+Media&pid=51>

### **My child is the only one coming to JLA from their primary school. As a parent, I am really worried. What provisions would be put in place?**

We have a number of students coming from a number of Primary Schools. We have ensured students who are coming to JLA on their own, are paired in a form with another student in the same situation to enable them to make new friends and settle in well.

### **What is ParentMail?**

ParentMail is our online payment system at the Academy. Money can be transferred on to your child's account via the app to pay for Academy lunches, trips and the purchasing of Academy items.

Further information on ParentMail can be found at

<https://www.josephleckieacademy.co.uk/page/?title=Parent+Mail+%28Payments%29&pid=48>.

### **Due to COVID, students have missed a lot of Year 6. How will they catch-up?**

The Academy staff have ensured the Year 7 curriculum takes this into account. The Year 7 curriculum in each subject area has been revised to ensure students have the opportunity to consolidate/catch up on missed Year 6 content.

### **Do you have a reward system at Joseph Leckie Academy?**

At JLA, we reward students using Vivo Class. This is a nation school rewards platform and students can be rewarded for; great academic work, good contribution to class, 100% attendance, involvement in extra-curricular activities and participation in sport.

***Further frequently asked questions are available on the Transition page of Joseph Leckie Academy website***





**Joseph Leckie  
Academy**

Walstead Road West, Walsall,  
West Midlands, WS5 4PG

Principal: Mr James Ludlow

Tel: 01922 721 071 Fax: 01922 641 497

email: [postbox@josephleckieacademy.co.uk](mailto:postbox@josephleckieacademy.co.uk)

web: [www.josephleckieacademy.co.uk](http://www.josephleckieacademy.co.uk)